



Smart phone application
(Bluetooth Option)



TF-100



TF-400



IR controller
(Standard)

ZigBee Controller
(Option)

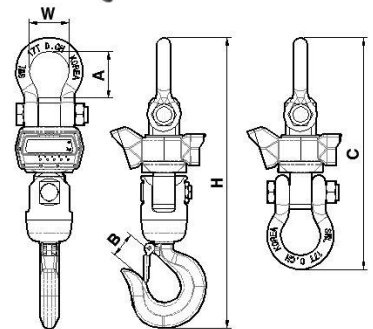

FEATURE

- ◆ Provided swivel hook or shackle(Optional)
- ◆ Big size display
- ◆ Easy to exchange battery pack(Li-Po battery)
- ◆ Infrared Remote controller(Standard)
- ◆ Interface with wireless remote display & controller (Option-ZigBee & Bluetooth)

MODEL	DIMMENSION				
	H	A	W	B	C
TCB - 15T	782	127	98	63	623
TCB - 20T	934	151	128	75	745
TCB - 30T	1125	164	146	82	866
TCB - 50T	1611	222	184	104	1074

MODEL	TCB-15T	TCB-20T	TCB-30T	TCB-50T
Capacity	15,000kg	20,000kg	30,000kg	50,000kg
Division	15kg	10kg	10kg	20kg
Max. Tare Weight	15,000kg	20,000kg	30,000kg	50,000kg
Product weight (hook type)	46kg	66kg	141kg	300kg
Display	5 digit LED (Character Size 30mm)			
Operating time	Approx. 60hr			
Battery	Lithium Polymer Battery 7.4V			
Temperature range	-10°C ~ 40°C			
Keypad	ON/OFF, Zero, Tare, Hold			
Display lamp	Low Battery, Zero, Tare, Hold			
Charging Adaptor	DC 12V, 1A			